

Technical Information

RID16

8-channel field indicator
with FOUNDATION Fieldbus™ or PROFIBUS® PA protocol



Field indicator for easy integration into existing fieldbus systems

Application

- Field indicator with 8 input channels and FOUNDATION Fieldbus™ or PROFIBUS® PA protocol for displaying process values and calculated values
- On-site display of process parameters in fieldbus systems
- CSA IS, NI
- ATEX Ex ia
- For intrinsically safe installation in zone 1 and zone 2
- Aluminum housing for Ex-applications as an option

Your benefits

- Bright, backlit LC indicator with bar graph, diagnostic symbols and plain text field
- Listener mode for up to 8 analog channels or digital statuses
- 8-channel indicator via function block interconnection in the case of FOUNDATION Fieldbus™
- Safe operation in hazardous areas thanks to international approvals such as
 - FM IS, NI

Function and system design

Measuring principle

Backlit display for up to 8 process values or calculated values of the fieldbus users connected to the fieldbus system via listener mode, or also via function block interconnection in the case of FOUNDATION Fieldbus™.

Measuring system

Endress+Hauser has a wide range of innovative products which can be used with the FOUNDATION Fieldbus™ and PROFIBUS® PA protocol. Together with the sensors and transmitters, the indicators form a complete measuring point for various applications in the industrial sector.

Device architecture

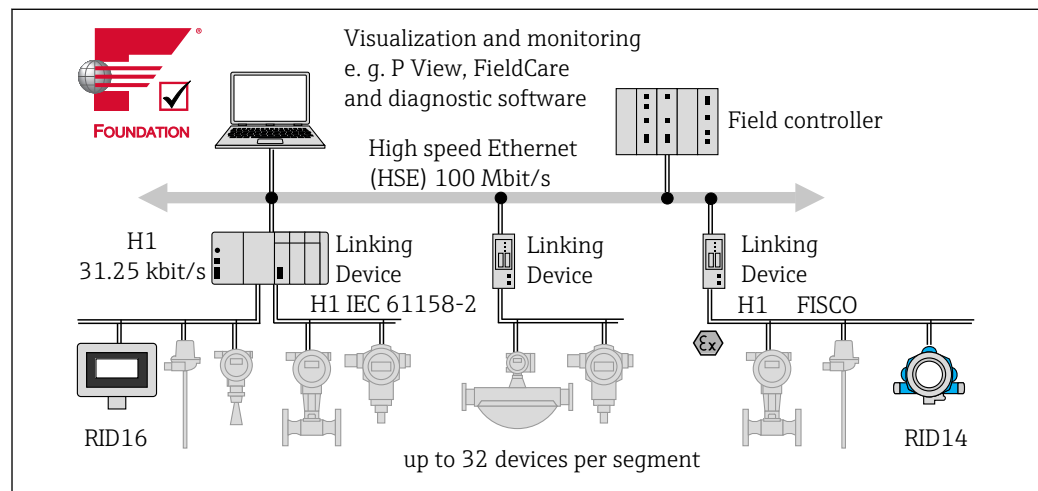

A0011300-EN

1 System integration via FOUNDATION Fieldbus™

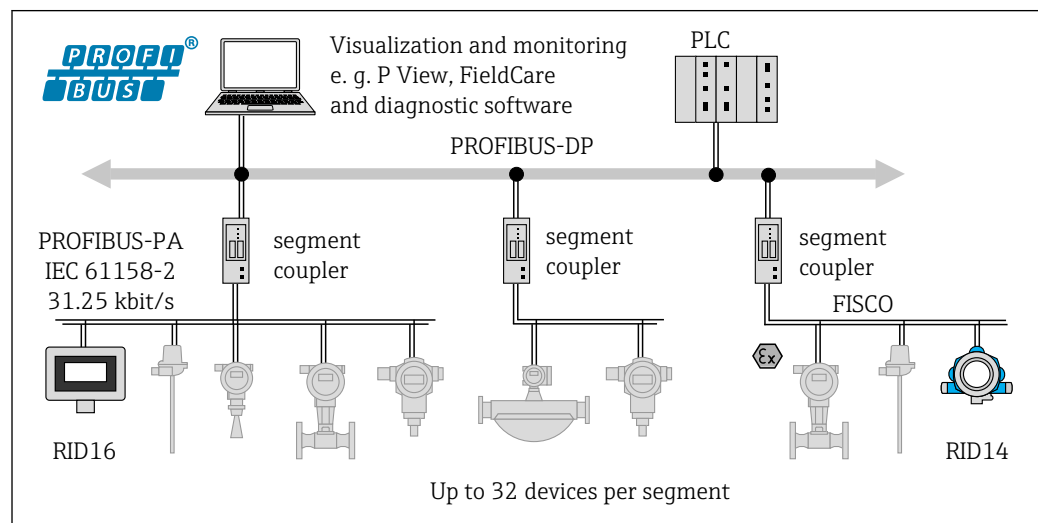

A0021436-EN

2 System integration via PROFIBUS® PA

The 8-channel indicator displays the measured values, calculated values and status information of the fieldbus users in a fieldbus network. In the listener mode, the device listens to the set fieldbus addresses and displays their specific values. Furthermore, values available on the bus can be also displayed via function block interconnection in the case of a FOUNDATION Fieldbus™ indicator.

Individual settings can be made for each channel. Analog values from the bus user are displayed as a five-digit number while digital values are displayed as plain text (ON/OFF, OPEN/CLOSE, numerical values). The process value status is indicated by icons or as plain text on the measured value display. Plain text display makes it possible to display alphanumeric character combinations, such as the TAG. For trend analysis, in addition to indicating measured values the indicator also has a bar graph,

with indicators for overranging and underranging, which can be scaled independently of the display value.

The device is powered by the fieldbus and can be used in hazardous areas up to temperature class T6.

Communication

Failure information Status message as per the fieldbus specification.

Switch-on delay 8 s

FOUNDATION Fieldbus™

- FOUNDATION Fieldbus™ H1, IEC 61158-2
- FDE (Fault Disconnection Electronic) = 0 mA
- Data transmission rate, supported baudrate: 31.25 kBit/s
- Signal encoding = Manchester II
- LAS (Link Active Scheduler), LM (Link Master) function is supported: Therefore, the indicator can assume the function of a Link Active Scheduler (LAS) if the current Link Master (LM) is no longer available. The device is supplied as a BASIC device. To use the device as an LAS, this must be defined in the distributed control system and activated by downloading the configuration to the device.
- According to IEC 60079-27, FISCO/FNICO

PROFIBUS® PA

- PROFIBUS® PA in accordance with EN 50170 Volume 2, IEC 61158-2 (MBP)
- FDE (Fault Disconnection Electronic) = 0 mA
- Data transmission rate, supported baudrate: 31.25 kBit/s
- Signal encoding = Manchester II
- Connection values in accordance with IEC 60079-11 FISCO, Entity

Protocol-specific data **FOUNDATION Fieldbus™**

Basic data

Device type	10CF (hex)
Device revision	02 (hex)
Node address	Default: 247
ITK Version	6.1.2
ITK Certification Driver No.	IT108100
Link Master (LAS) capable	Yes
Choice of Link Master / Basic Device	Yes; factory setting: Basic Device
Number of VCRs	44
Number of link objects in VFD	50

Virtual communication relationships (VCRs)

Permanent entries	1
Client VCRs	0
Server VCRs	10
Source VCRs	43
Sink VCRs	0
Subscriber VCRs	43
Publisher VCRs	43

Link settings

Slot time	4
Min. Inter PDU delay	10
Max. response delay	28

Blocks

Block description	Block index	Permanent	Block execution time	Block category
Resource	400	YES		Extended
Display Transducer	500	YES		Manufacturer-specific
Advanced Diagnostic	600	YES		Manufacturer-specific
PID	1100	NO	30 ms	Standard
Input Selector 1	1200	NO	30 ms	Standard
Input Selector 2	1300	NO	30 ms	Standard
Arithmetic	1500	NO	30 ms	Standard
Integrator	1400	NO	30 ms	Standard

*Brief block description**Resource Block:*

The Resource Block contains all the data that clearly identify and characterize the device. It is an electronic version of a nameplate on the device. In addition to parameters required to operate the device on the fieldbus, the Resource Block makes information available such as the order code, device ID, software revision, order ID etc.

Display Transducer:

The parameters of the "Display" Transducer Block enable the configuration of the display.

Advanced Diagnostic:

All the parameters for self-monitoring and diagnostics are grouped in this Transducer Block.

PID:

This function block contains input channel processing, proportional integral-differential control (PID) and analog output channel processing. The following can be realized: Basic controls, feedforward control, cascade control and cascade control with limiting.

Input Selector (ISEL):

The Input Selector Block enables the selection of up to four inputs and generates an output based on the configured action.

Integrator (INT):

The Integrator Block integrates one or two variables over time. The Block compares the integrated or totalized value to limit values and generates a discrete output signal if the limit value is reached. It can be selected from six integration types.

Arithmetic (ARITH):

The Arithmetic function block permits standard computing operations and compensations. It supports the addition, subtraction, multiplication and division of values. In addition, mean values are calculated and flow values are compensated for (linear, quadratic compensation) in this block.

PROFIBUS® PA

Basic data

Indicator for PROFIBUS PA, for use in conjunction with PROFIL 2 and PROFIL 3 (3.0, 3.01 and 3.02) devices	
Device drivers	Where to obtain the device drivers: FieldCare/DTM: www.endress.com/download → product root RID14 or RID16 → search area "Software" → "Drivers"
Write protection	Write protection activated by hardware setting (DIP switch)

Power supply

Electrical connection

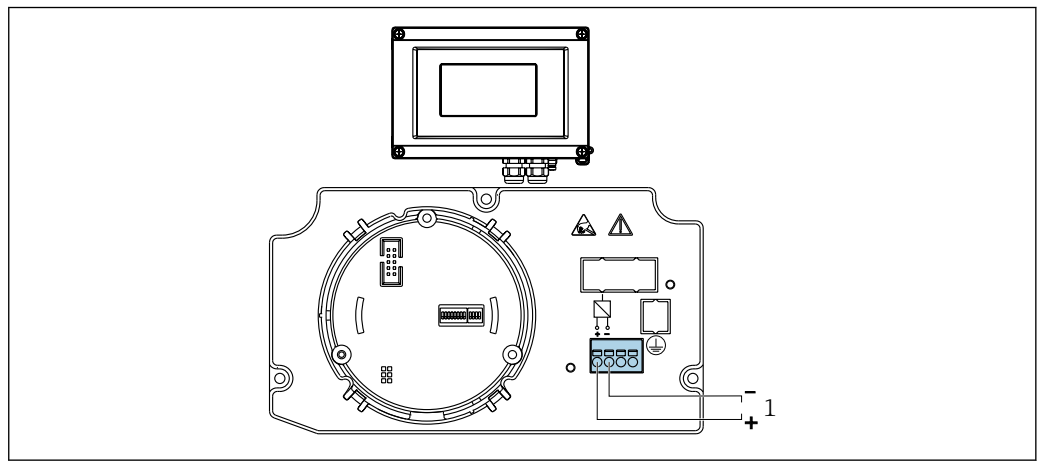

3 Terminal assignment of the field indicator
1 Fieldbus connection

Supply voltage	Voltage is supplied via the fieldbus. $U = 9 \text{ to } 32 \text{ V}_{\text{DC}}$, polarity-independent (max. voltage $U_b = 35 \text{ V}$).
Mains voltage filter	50/60 Hz
Current consumption	$\leq 11 \text{ mA}$
Cable entry	The following cable entries are available: <ul style="list-style-type: none"> ▪ Thread NPT1/2 ▪ Thread M16

Installation

Orientation	No restrictions, the orientation depends on the readability of the display.
Mounting location	Wall or pipe mounting (see "Accessories" → 9)

Environment

Ambient temperature range	-40 to +80 °C (-40 to +176 °F)
	<p>i The display can react slowly at temperatures < -20 °C (-4 °F). At temperatures < -30 °C (-22 °F) the readability of the display can no longer be guaranteed.</p>
Storage temperature	-40 to +80 °C (-40 to +176 °F)
Altitude	Up to 4 000 m (13 100 ft) above mean sea level in accordance with IEC 61010-1, CSA 1010.1-92
Climate class	As per IEC 60654-1, Class C
Humidity	<ul style="list-style-type: none"> ■ Condensation permitted as per IEC 60 068-2-33 ■ Max. rel. humidity: 95% as per IEC 60068-2-30
Degree of protection	IP67. NEMA 4X.
Shock and vibration resistance	10 to 2 000 Hz at 5g as per IEC 60 068-2-6
Electromagnetic compatibility (EMC)	<p>CE compliance</p> <p>Electromagnetic compatibility in accordance with all the relevant requirements of the IEC/EN 61326 series and NAMUR Recommendation EMC (NE21). For details refer to the EU Declaration of Conformity.</p> <p>Interference immunity as per IEC/EN 61326 series, industrial requirements.</p> <p>Interference emission as per IEC/EN 61326 series, Class B equipment.</p>
Measuring category	Measuring category II as per IEC 61010-1. The measuring category is provided for measuring on power circuits that are directly connected electrically with the low-voltage network.
Degree of contamination	Pollution degree 2 as per IEC 61010-1.

Mechanical construction

Design, dimensions

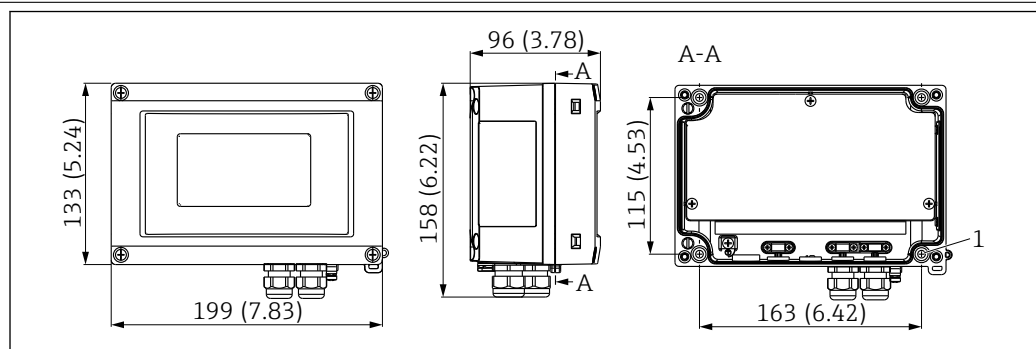

4 Dimensions of the field indicator; dimensions in mm (in)

Plastic housing for general applications, or optional aluminum housing

Weight	<ul style="list-style-type: none"> ■ Plastic housing Approx. 500 g (1.1 lb) ■ Aluminum housing Approx. 1.7 kg (3.75 lb)
---------------	---

Material	Housing	Nameplate
	Fiber-glass reinforced plastic PBT-GF30	Laser inscription
	Aluminum (AlSi12, AC-44100 or AlSi10Mg(Fe), AC-43400) (optional)	Laser-writable film, polyester

Terminals Screw terminals for cables up to max. 2.5 mm² (14 AWG) plus ferrule

Operability

Local operation

Display elements

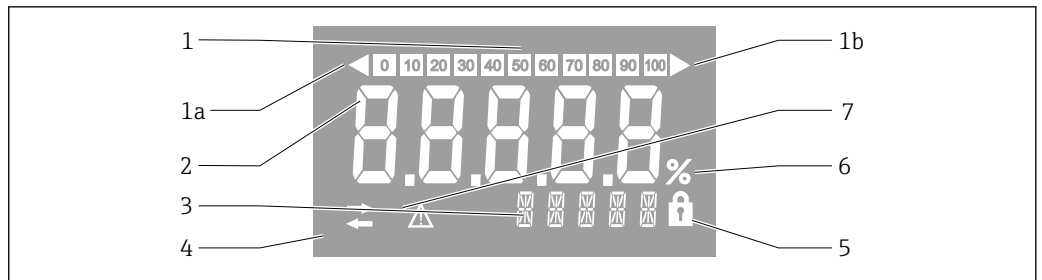

5 LC display of the field indicator (backlit)

- 1 Bar graph display in increments of 10% with indicators for underranging (item 1a) and overranging (item 1b)
- 2 Measured value display, digit height 26 mm (1.2 in), status indication "Bad measured value status"
- 3 14-segment display for units and messages
- 4 "Communication" symbol
- 5 "Configuration locked" symbol
- 6 Unit "%"
- 7 "Uncertain measured value status" symbol

Display range
-9999 to +99999

DIP switches

PROFIBUS® PA: Configuration of the bus address of the values displayed (max. 2 if configuring via DIP switches) and the hardware write protection

FOUNDATION Fieldbus™: Configuration of the hardware write protection

Remote operation

FOUNDATION Fieldbus™

FOUNDATION Fieldbus™ functions and device-specific parameters are configured via fieldbus communication. Special configuration systems from different manufacturers are available for this purpose.

Process control systems	Asset management systems
Emerson DeltaV	Endress+Hauser FieldCare/DeviceCare
Rockwell Control Logix/FFLD	National Instruments NI-Configurator (≥ 3.1.1)
Honeywell EPKS	Emerson AMS and Handheld FC375
Yokogawa Centum CS3000	Yokogawa PRM EDD/DTM
ABB Freelance System / 800xA	Honeywell FDM
Invensys IA Series	PACTware

PROFIBUS® PA

The parameters can be configured either remotely via the DTM and configuration software or onsite via DIP switches.

Certificates and approvals

CE mark	The measuring system meets the legal requirements of the applicable EC guidelines. These are listed in the corresponding EC Declaration of Conformity together with the standards applied. Endress+Hauser confirms successful testing of the device by affixing to it the CE mark.
EAC mark	The product meets the legal requirements of the EEU guidelines. The manufacturer confirms the successful testing of the product by affixing the EAC mark.
Ex approval	Information about currently available Ex versions (ATEX, FM, CSA, etc.) can be supplied by your E+H Sales Center on request. All explosion protection data are given in a separate documentation which is available upon request.
CSA GP	CSA General Purpose
Other standards and guidelines	<ul style="list-style-type: none"> ■ IEC 60529: Degrees of protection provided by enclosures (IP code) ■ IEC 61010-1: Safety requirements for electrical equipment for measurement, control and laboratory use ■ IEC 61326-Serie: Electromagnetic compatibility (EMC requirements) ■ NAMUR: International user association of automation technology in process industries (www.namur.de)

Ordering information

Detailed ordering information is available from the following sources:



- In the Product Configurator on the Endress+Hauser website: www.endress.com -> Click "Corporate" -> Select your country -> Click "Products" -> Select the product using the filters and search field -> Open product page -> The "Configure" button to the right of the product image opens the Product Configurator.
- From your Endress+Hauser Sales Center: www.addresses.endress.com

Product Configurator - the tool for individual product configuration

- Up-to-the-minute configuration data
- Depending on the device: Direct input of measuring point-specific information such as measuring range or operating language
- Automatic verification of exclusion criteria
- Automatic creation of the order code and its breakdown in PDF or Excel output format
- Ability to order directly in the Endress+Hauser Online Shop

Accessories

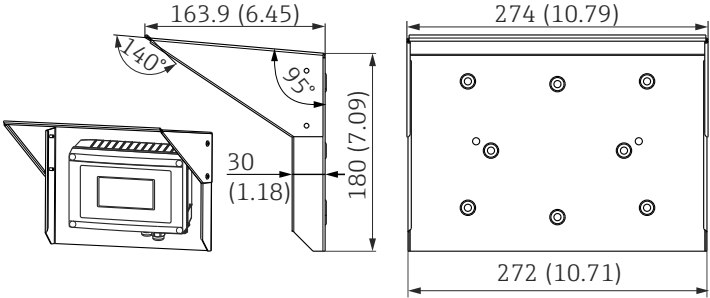
Various accessories are available for the device, and these can be ordered with the device or at a later stage from Endress+Hauser. Detailed information on the order code in question is available from your local Endress+Hauser Sales Center or on the product page of the Endress+Hauser website: www.endress.com.

Device-specific accessories	Designation	Type
	Blanks (blind)	2 pieces
	Cable gland	2x M16 2x adapter M16 to M20 2x adapter M16 to NPT1/2
	Mounting set wall/pipe (for pipes \varnothing 1-5 inch)	<ul style="list-style-type: none"> ■ Plastic housing ■ Aluminum housing
	Weather protection cover	 <p> 6 Dimensions in mm (in)</p> <p style="text-align: right; font-size: small;">A0021548</p>

Communication-specific accessories	Designation	Type
	Fieldbus connector FOUNDATION Fieldbus™:	FF plug 7/8"
	Fieldbus connector PROFIBUS® PA:	<ul style="list-style-type: none"> ■ PA plug 7/8" ■ PA plug M12
	Interface cable	Commubox FXA291 incl. FieldCare Device Setup + DTM Library

Supplementary documentation

- System components and data manager - solutions to complete your measuring point:
FA00016K/09
- Competence brochure: FOUNDATION Fieldbus - process automation with digital fieldbus technology: CP00003S/04
- Competence brochure: PROFIBUS - process automation with digital fieldbus technology:
CP00005S/04
- Operating Instructions for field display unit RID16 with FOUNDATION Fieldbus™ protocol:
BA00284R/09
Operating Instructions for field display unit RID16 with PROFIBUS® PA protocol: BA01268K/09
- Ex-related additional documentation:
ATEX II2G Ex ia IIC Gb: XA00099R/09

www.addresses.endress.com
