

Conductivity Sensor for High-Temperature Applications *ConduMax W CLS 13*

**Two-electrode sensors
with cell constant $k = 0.01 \text{ cm}^{-1}$ or $k = 0.1 \text{ cm}^{-1}$**



Application

This conductivity sensor is designed for industrial and power plant applications (e.g. condensate measurement) where low conductivities must be measured under high pressures and temperatures.

The measuring range of the sensors depends on the cell constant k .

- $k = 0.01 \text{ cm}^{-1}$: 0.04 ... 20 $\mu\text{S/cm}$
- $k = 0.1 \text{ cm}^{-1}$: 0.1 ... 200 $\mu\text{S/cm}$

Sensors with a Pt 100 temperature sensor are used together with conductivity measuring instruments equipped with automatic temperature compensation:

- Mycom S CLM 153
- Liquisys M CLM 223/253
- MyPro CLM 431

For measurement of specific resistance, $\text{M}\Omega \cdot \text{cm}$ measuring ranges are available in the menus of these transmitters.



With ATEX approval for application in hazardous areas.

Your benefits

- Optimum adaptation to process conditions or mounting place due to different designs
- Mounting in pipes or flow chambers
- Application with temperatures of up to 250 °C / 482 °F and pressures of up to 40 bar / 580 psi
- Simple measuring cable connection due to large connection compartment
- Quality certificate stating the individual cell constant

With
quality certificate



Function and system design

Measuring principle

Conductive conductivity measurement

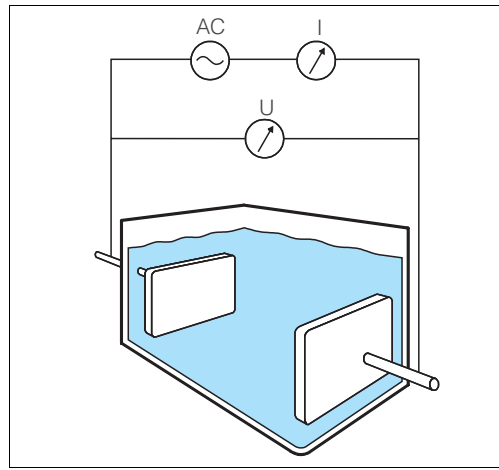

Conductive conductivity measurement

AC Power supply
I Current meter
U Voltage meter

The conductivity of liquids is measured with a measuring system that has two coaxially arranged electrodes like a capacitor. The electric resistance or its reciprocal value, the conductance G , is measured according to Ohm's law. The specific conductivity κ is determined using the cell constant k that is dependent on the sensor geometry.

Important properties ConduMax W CLS 13

- **Electrodes**
ConduMax W CLS 13 has especially large coaxial measuring electrodes. These allow high flow rates and high accuracy.
- **Temperature compensation**
In addition, a Pt 100 temperature sensor is installed in the inside electrode to measure the medium temperature. The high thermal conductivity allows fast adjustment of the sensor to the medium temperature, thereby guaranteeing precise automatic temperature compensation in the connected measuring transmitter.
- **Durability**
The sensors are distinguished by high thermal, chemical and mechanical resistances. The maximum operating pressure is 40 bar / 580 psi, the maximum operating temperature is 250 °C / 482 °F.
- **Use in superheated steam or ultrapure water**
Special sealing materials are available for use in superheated steam or ultrapure water at high temperatures. For these applications, no nominal durability of the Kalrez standard material can be given.

Measuring system

A complete measuring system comprises:

- a CLS 13 conductivity sensor
- a transmitter, e.g. Mycom S CLM 153
- a CYK 71 or CYK 71-Ex measuring cable

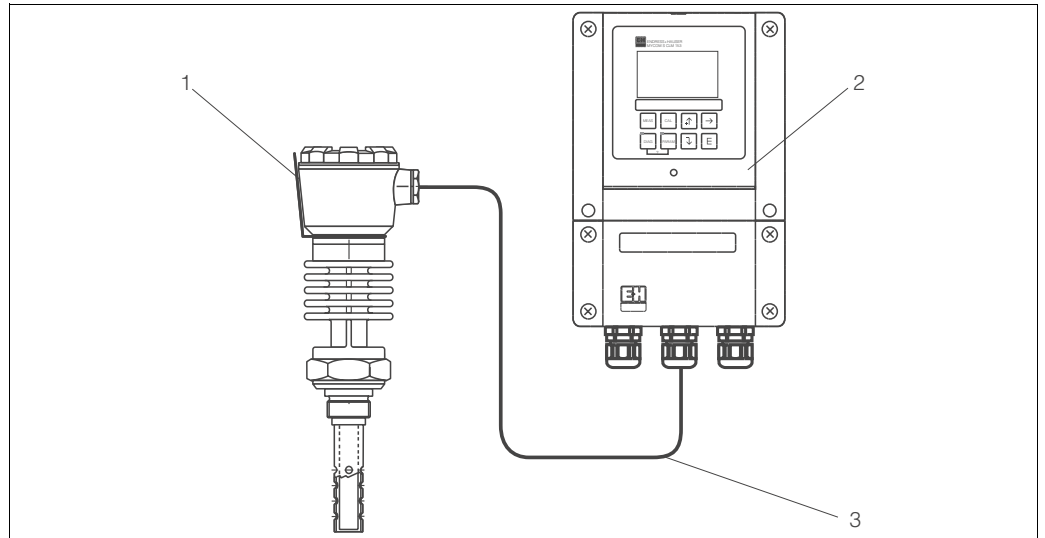

Measuring system example

- 1 ConduMax W CLS 13
- 2 Transmitter Mycom S CLM 153
- 3 Measuring cable

C07-CLS13xxx-14-05-00-xx-001.eps

Input

Measured values

Conductivity
Temperature

Cell constant k

Depending on ordered version:
k = 0.01 cm⁻¹
k = 0.1 cm⁻¹

Measuring ranges

Conductivity	(referenced to water at 25 °C / 77 °F)
k = 0.01 cm ⁻¹ :	0.04 µS/cm ... 20 µS/cm
k = 0.1 cm ⁻¹ :	0.1 µS/cm ... 200 µS/cm
Temperature	-20 ... 240 °C / -4 ... 464 °F

Temperature sensor

Pt 100

Cable specification

The ConduMax W is connected to the transmitter using the special measuring cable CYK 71 or CYK 71-Ex.

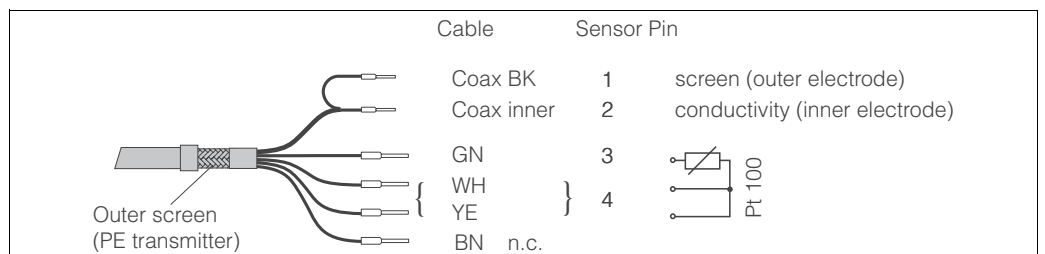

Special measuring cable CYK 71 / CYK 71-Ex

C07-CYK71xxx-00-11-00-en-001.eps

Installation

Installation instructions

The sensors are mounted directly in a pipe via the thread G1 or NPT 1" process connections. When mounting the sensor, make sure that the measuring surfaces are completely wetted by the medium during operation. When working in ultrapure water, ingress of air must be avoided since dissolved air, particularly CO₂, may increase conductivity by up to 3 μS/cm. The minimum immersion depth is 50 mm / 1.97".

Environment

Ingress protection

IP 67

Process

Process temperature

-20 ... 250 °C / -4 ... 482 °F

Process pressure

max. 40 bar / 580 psi

Pressure/temperature load curve

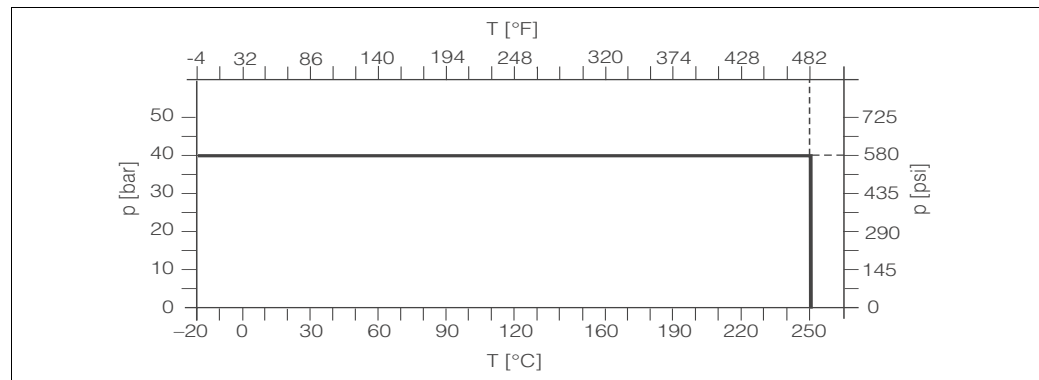

C07-CLS13xxx-05-00-en-001.eps

Pressure/temperature load curve of CLS 13

Mechanical construction

Design, dimensions

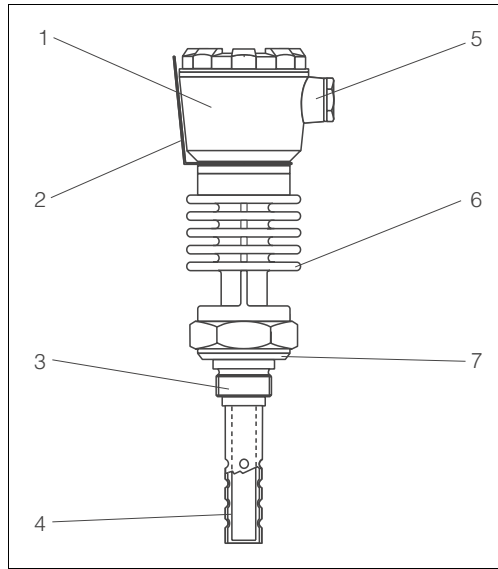

CLS 13 design

- 1 Connection head
- 2 Nameplate
- 3 Internal thread
- 4 Electrodes (coaxially arranged)
- 5 Measuring cable connection Pg 16 / NPT 1/2
- 6 Dissipator
- 7 Sealing surface acc. to DIN 3852 Bl 2, Form A

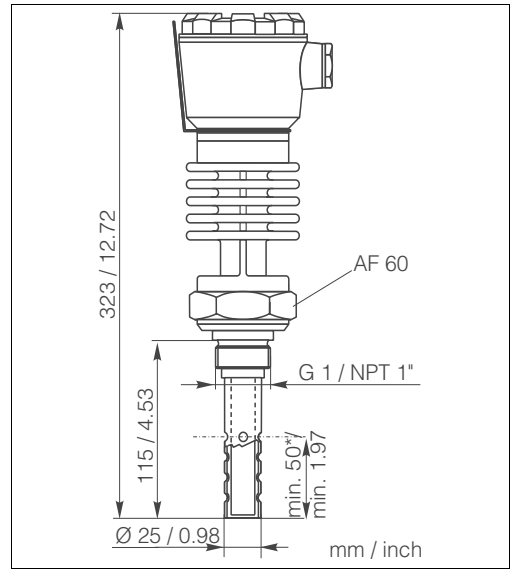

CLS 13 dimensions

* Immersion depth

Weight 1.7 kg / 3.7 lb.

Materials	Electrodes	stainless steel 1.4571 (AISI 316Ti)
	Process connection	stainless steel 1.4571 (AISI 316Ti)
	Connection head	die-cast aluminium
	Dissipator	die-cast aluminium
	Sealing of electrodes	Kalrez, ceramics

Process connection G 1 or NPT 1" thread

Cable connection PG 16 cable gland or NPT 1/2" cable entry

Certificates and approvals

Ex approval

- ATEX II 1G EEx ia IIC T2 / T3 / T4 / T6
- FM in combination with the MyPro CLM 431 and Mycom S CLM 153 transmitters for all product versions listed in the product structure (see Ordering Information)

Quality certificate with statement of the individual cell constant

Ordering information

Product structure ConduMax W CLS 13

Measuring range and cell constant	
A	Measuring range: 0.04 ... 20 µS/cm (k = 0.01)
B	Measuring range: 0.1 ... 200 µS/cm (k = 0.1)
Process connection and materials	
1D	Thread G 1, stainless steel 1.4571 (AISI 316Ti)
1K	Thread NPT 1", stainless steel 1.4571 (AISI 316Ti)
Measuring cable connection	
1	Cable gland Pg 16
5	Cable entry NPT ½"
Temperature sensor	
A	Integrated Pt 100 temperature sensor
CLS 13-	complete order code

Accessories

Measuring cables

- Special measuring cable / extension cable CYK 71
for two-electrode conductivity sensors with integrated temperature sensor,
1 low-noise coaxial line, 4 auxiliary cores at 0,75 mm² each with a common screen, outer
diameter 7 mm / 0,25"

Sold by the metre, minimum length 5 m / 15 ft Order no. 50085333
 Length 5 m / 15 ft Order no. 50088280
 Length 10 m / 30 ft Order no. 50088281
 Length 50 m / 150 ft Order no. 50088284
 Length 100 m / 300 ft Order no. 50088285

- Special measuring cable / extension cable CYK 71-Ex
for Ex applications,
see CYK 71, but with a blue sheath

Sold by the metre, minimum length 5 m / 15 ft Order no. 50085673

- Junction box VBM
for cable extension, with 10 terminals, IP 65 / NEMA 4X

Cable entry Pg 13,5 Order no. 50003987
 Cable entry NPT ½" Order no. 51500177

- Junction box VBM-Ex
for cable extension in hazardous areas, with 10 high-impedance terminals (blue),
IP 65 / NEMA 4X;
order no. 50003991

Calibration solutions

- Calibration solutions
Precision solutions referred to SRM (Standard Reference Material) of NIST for qualified
calibration of conductivity measuring systems according to ISO, accuracy ± 0,5 %, with
temperature table,
– CLY 11-A
74 µS/cm (reference temperature 25 °C / 77 °F), 500 ml;
order no. 50081902
– CLY 11-B
149,6 µS/cm (reference temperature 25 °C / 77°F), 500 ml;
order no. 50081903

Calibration set

- Calibration set ConCal
Conductivity calibration set for ultrapure water applications,
complete, factory-calibrated measuring set with certificate, traceable to SRM of NIST and DKD,
comparative measurement in ultrapure water applications up to 10 µS/cm
– 230 V AC, order no. 50083777
– 115 V AC, order no. 50083778
- Recalibration ConCal
Factory recalibration and new issue of calibration certificate, traceable to SRM of NIST and
DKD, factory calibration procedure according to ASTM D-5391-93;
order no. 51502486

Related products

- Conductive conductivity sensor ConduMax W CLS 12
For process temperatures up to 160 °C / 320 °F and process pressures up to 40 bar / 580 psi,
for ordering information, see the technical information of CLS 12

Documentation

Ex documentation

- Conductivity sensors for application in hazardous areas, XA 083C/07/a3;
order no. 51512902

Transmitters

- Mycom S CLM 153, Technical Information TI 234C/07/en; order no. 51503792
- Liquisys M CLM 223/253, Technical Information TI 193C/07/en; order no. 51500279
- MyPro CLM 431, Technical Information TI 202C/07/en; order no. 51500563

Calibration solutions

- Precision calibration solution CLY 11, Technical Information TI 162C/07/en; order no. 50086574

Calibration set

- ConCal, Technical Information TI 163C/07/en; order no. 50085983

Related products

- ConduMax W CLS 12, Technical Information TI 082C/07/en; order no. 50059349

Endress+Hauser GmbH+Co. KG

Instruments International
P.O. Box 2222
D-79574 Weil am Rhein
Germany

Tel. (07621) 975-02
Tx 773926
Fax (07621) 975 345
e-mail: info@ii.endress.com

Internet:

<http://www.endress.com>

Endress + Hauser

The Power of Know How

